



Gate Valves Type Pressure Seal

Class 900 DN 50-500 (2" – 20")

Carbon, Alloy and Stainless Steel

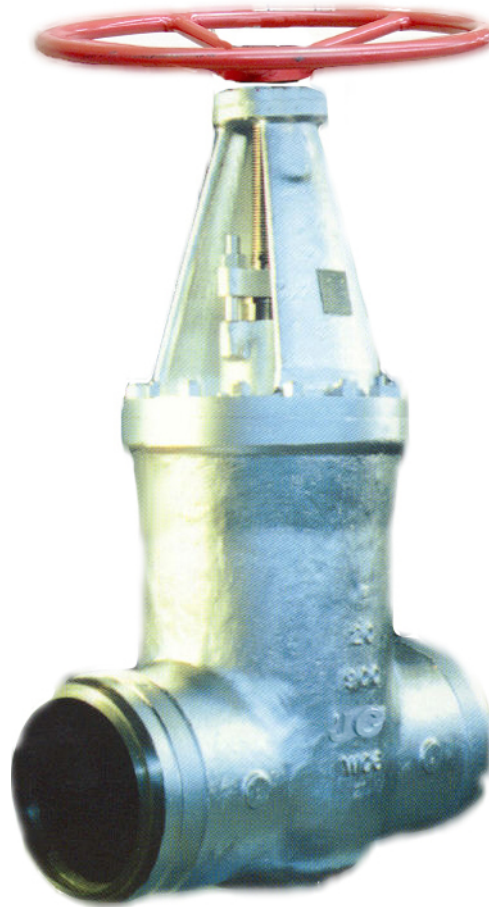
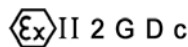

Fig. VC900PS

Design: ASME B16.34





Gate Valves Class 900

Type Pressure Seal

Parts and materials

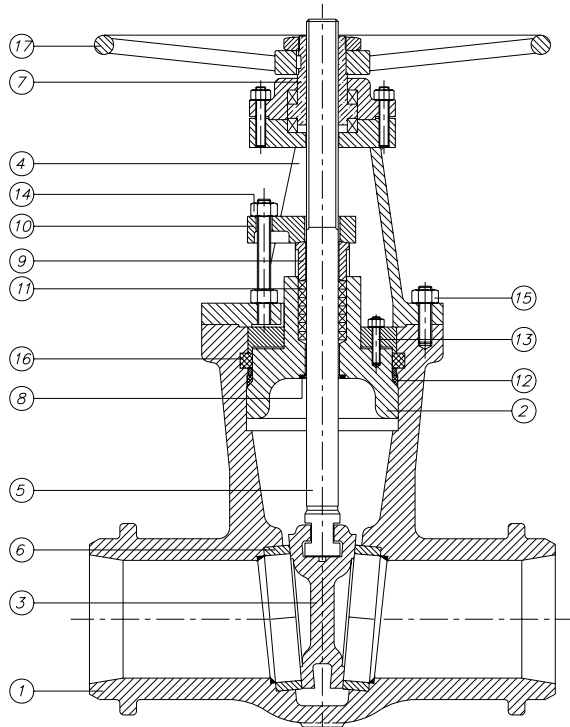

Trim Material

API 600 Trim No.	Stem / Backseat	Seating Surface Body / Wedge
1	13% Cr	13% Cr
2	SS 304	SS 304
3	SS310	SS310
4	13% Cr	13% Cr (Hard)
5 or 5A	13% Cr	HF
6	13% Cr	13% Cr / Cu Ni
7	13% Cr	13% Cr / 13% Cr (Hard)
8 or 8A	13% Cr	HF / 13% Cr
9	Monel	Monel
10	SS 316	SS 316
11 or 11A	Monel	HF / Monel
12 or 12A	SS 316	HF / SS 316
13	Alloy 20	Alloy 20
14 or 14A	Alloy 20	HF / Alloy 20

HF: Hard Facing using CoCr welding alloy (Stellite)

Item	Description	Material			
		Carbon Steel	Carbon Steel (Low Temp.)	Alloy Steel	Stainless Steel
1	Body	A 216 Gr.WCB	A 352 Gr.LCB	A 217 Gr.C5	A 351 Gr.CF8M
2	Bonnet	A 216 Gr.WCB	A 352 Gr.LCB	A 217 Gr.C5	A 351 Gr.CF8M
3	Wedge	A 216 Gr.WCB + Stellite	A 352 Gr.LCB + Stellite	A 217 Gr.C5 + Stellite	A 351 Gr.CF8M + Stellite
4	Yoke	A 216 Gr.WCB	A 352 Gr.LCB	A 217 Gr.C5	A 351 Gr.CF8M
5	Stem	A 182 Gr.F6a	A 182 Gr.F304	A 182 Gr.F6a	A 182 Gr.F316
6	Seat Ring	A 105 + Stellite	A 182 Gr.F304 + Stellite	A 182 Gr.F6a + Stellite	A 182 Gr.F316 + Stellite
7	Stem Nut	B 148 / A 439 Gr.D2	B 148 / A 439 Gr.D2	B 148 / A 439 Gr.D2	B 148 / A 439 Gr.D2
8	Backseat	Stellite	Stellite	Stellite	Stellite
9	Gland	A 105	A 105	A 182 Gr.F6a	A 182 Gr.F316
10	Gland Flange	A 105	A 105	A 105	A 182 Gr.F304
11	Stem Packing	Graphited	Graphited	Graphited	Graphited
12	Gasket	A 182 Gr.F304	A 182 Gr.F304	A 182 Gr.F304	A 182 Gr.F316
13	Bonnet Bolt & Nut	A 193 Gr.B7 / A 194 Gr.2H	A320 Gr. L7 / A194 Gr. 7	A 193 Gr.B7 / A 194 Gr.2H	A 193 Gr.B7 / A 194 Gr.2H
14	Bolt & Nut	A 193 Gr.B7 / A 194 Gr.2H	A 193 Gr.B7 / A 194 Gr.2H	A 193 Gr.B7 / A 194 Gr.2H	A 193 Gr.B7 / A 194 Gr.2H
15	Yoke Bolt & Nut	A 193 Gr.B7 / A 194 Gr.2H	A 193 Gr.B7 / A 194 Gr.2H	A 193 Gr.B7 / A 194 Gr.2H	A 193 Gr.B7 / A 194 Gr.2H
16	Segmental Ring	A 515 Gr.70	A 182 Gr.F304	A 182 Gr.F304	A 182 Gr.F316
17	Handwheel	Carbon Steel	Carbon Steel	Carbon Steel	Carbon Steel



Gate Valves Class 900

Type Pressure Seal

Dimensions

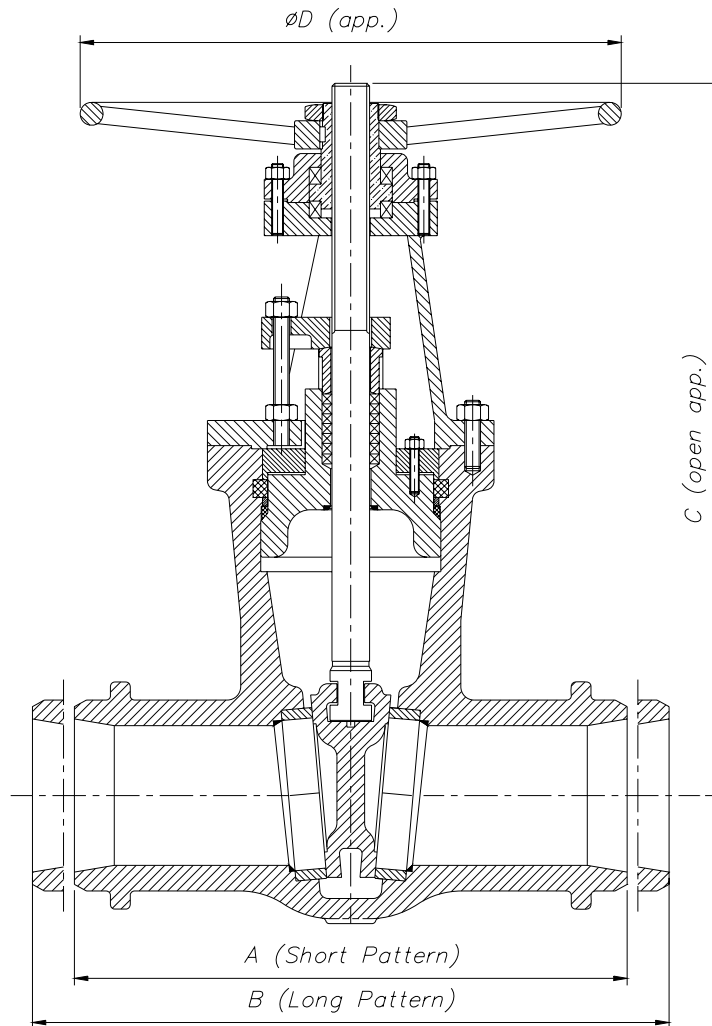

DN	A	B	C	ØD	WEIGHT
50 (2")	216	368	545	250	50
65 (2½")	254	419	575	300	65
80 (3")	305	381	595	300	75
100 (4")	356	457	720	400	130
125 (5")	432	559	850	500	205
150 (6")	508	610	970	500	265
200 (8")	660	737	1140	600	430
250 (10")	787	838	1345	680	680
300 (12")	914	965	1615	760	950
350 (14")	991	1029	1651	760	1290
400 (16")	1092	1130	2362	910	1850
450 (18")	1219	1219	2450	910	2250
500 (20")	1321	1321	2550	950	2785

(*) Dimensions in mm and weight in kg.



Gate Valves Class 900

Type Pressure Seal

General Characteristics, Cv, P&T Rating

GENERAL CHARACTERISTICS	Fig. VC900PS			
DESIGN STANDARDS				
Valves design	ASME B16.34			
End to End Dimensions	ASME B16.10 & ISO 5752			
Flanged Dimensions	ASME B16.5 & ISO 7005-1 Part. 1	ASME B16.47	BS 3293	MSS SP-44
Buttweld Dimensions	ASME B16.25			
Visual Inspection	MSS SP- 55			
Marking	MSS SP-25 & ISO 5209			
TESTS AND CERTIFICATES				
Pressure testing	API 598 & ISO 5208	BS 6755 Part. 1	MSS SP-61	
Other	ATEX, CE			

Cv Values in U.S. Gallons/min.

DN	Cv	DN	Cv
50 (2")	225	250 (10")	5450
65 (2½")	350	300 (12")	7450
80 (3")	480	350 (14")	9500
100 (4")	750	400 (16")	11900
125 (5")	1300	450 (18")	14500
150 (6")	1850	500 (20")	18500
200 (8")	4300		

Pressure-Temperature (STANDARD CLASS According to ASME B16.34)

Temp °C	MATERIAL			
	A216 WCB Bar	A352 LCB Bar	A217 C5 Bar	A351 CF8M (**) Bar
-29 to 38	153,0	143,7	155,0	148,8
95	139,5	135,7	154,0	128,2
150	135,7	131,9	148,1	115,8
205	130,9	127,5	145,7	106,1
260	123,7	120,2	137,5	98,9
315	113,0	110,2	125,1	93,4
345	110,9	108,2	121,6	91,6
375	110,2		117,5	89,9
400	104,0		109,2	88,2
425	85,1		105,1	87,2
450	55,5		99,9	86,5
485	35,5		76,5	85,8
510	21,4		56,8	79,9
540	10,7		41,0	72,3
565			29,6 *	71,0 *
595			20,7 *	63,0 *
620			12,7 *	48,9 *
650			7,2 *	38,2 *
675				30,3 *
705				24,1 *
735				20,0 *
760				15,5 *
790				12,1 *
815				8,6 *

* FOR WELD END VALVES ONLY. FLANGED END RATINGS TERMINATE AT 540°C

** A351 CF8M at temperatures over 538°C (1000°F) to be used only if Carbon contents is 0,04% or higher.